

AGENDA

Wednesday, March 18, 2026 at 3:00 p.m.

Hybrid Meeting on Zoom or in-person **Town Hall Conference Room 237** **(Note new location for in-person meeting)**

Committee members should use the individual link emailed to them prior to the meeting to join via Zoom.

The Committee welcomes public comment during the meeting. The public may join the meeting by registering in advance at:

https://ogunquitpd-org.zoom.us/webinar/register/WN_ZZ8bXaMERMMSOBRK7VtdWGg

After registering, you will receive a confirmation email containing information about joining the webinar.

The Ogunquit Bicycle/Pedestrian Committee respects the time of our volunteer committee members, the public, and the Town of Ogunquit staff. We strive to keep our meetings to an hour each of the ten months that we meet. We take a summer break in July and August each year.

Welcome/Roll Call

Approval of Minutes – January 21, 2025

Unfinished Business

1. Ogunquit Police Topics/Micromobility Education – Detective Joe LaBier
 - Bruce will use the Ogunquit, Kennebunk and Portsmouth documents to prepare a draft of a tri-fold brochure for us to have available for this summer.
2. League of American Bicyclists – Bike Friendly Community Application
 - Congratulations! Ogunquit recognized as Bike Friendly Community at the Bronze level.
 - Michele to draft a PR plan for communicating the BFC award and distribute via email for discussion prior to the March meeting.
 - Michele recommended that we schedule a workshop to review the BFC survey information and the BFC Report Card to look for ways we can make Ogunquit more bike friendly.
3. Village Partnership Initiative
 - Next Step: Committee to make an official ask to the Select Board and Town for items from the VPI to be implemented along with a cost estimate for each ask.
 - Have a short deadline for getting items onto Warrant Article

- Michele sent message to Tom Torno about painting recommendations. Waiting to hear back from Tom.
- Based on the response from Tom Torno, Michele indicated she would take off-line and draft a letter to send to the Town Manager requesting funding to be included in the warrant for painting.

4. Bike Rack Locations

- Ilene Kanoff researched bike racks and provided the attached quote from Saris.
 - It appears that our budget will only accommodate two five-loop racks that will need assembly.
- The committee recommends the following bike rack location changes/additions:
 - Add two racks to North Beach
 - Move the rack outside the gate at Footbridge Beach to inside
 - Add two racks to Main Beach
 - Add one rack to Jacob's Lot
 - Eliminate one rack at Obed's Lot entrance
 - Eliminate one rack at Ledge Park
- We need to schedule a meeting with Elle on exact bike rack locations over the winter in late April.
- The Town Manager has received approval from the Select Board to donate one used bike rack to the Great Works Land Trust for use at the Boston Preserve trail head. Need to identify which rack and exact location.

5. Sidewalk Projects

- Sidewalk Project Documentation provided by the Town Manager.

New Business

Other Business

1. Next meeting date: Wednesday, April 15, 2026 at 3:00 p.m. (Bruce will be absent)

Public Comment

- The "Raise Hand" function in Zoom will be used to recognize those who wish to participate. Chat messages or Facebook Live Comments will not be acknowledged.
- We ask that people keep comments to a maximum of 3 minutes, that comments be respectful, and that you begin by stating your name and your affiliation with Ogunquit (i.e., resident, taxpayer, voter, business owner, etc.).

Adjournment



SALES QUOTE

Sales Quote: QUO-05405
 Sales Quote Date: 2/26/2026

Sold To:
 Town of Ogunquit
 31 School St
 Ogunquit, ME 03907-3734
 USA

Ship To:
 Town of Ogunquit
 31 School St
 Ogunquit, ME 03907-3734
 USA

Salesperson David Hayes
 Email dhayes@saris.com
 P.O. Number Bike racks
 P.O. Date 2/26/2026

Customer ID
 Cust Phone
 Cust Fax
 Cust Email ikanoff@ogunquit.gov

Item No.	Description	Quantity	Unit Price	Total Price
27215BLK	BIKE DOCK,2.375,FM,PC,BLK	10.00	\$211.50	\$2,115.00
28360	RAIL KIT,6 BIKE,CORRAL	2.00	\$225.00	\$450.00
28359	RAIL KIT,4 BIKE,CORRAL	2.00	\$157.50	\$315.00
28362	CONNECTOR KIT,RAIL,CORRAL	2.00	\$117.00	\$234.00
6259	SPIKE ANCHOR KIT 3/8 X 6	2.00	\$26.10	\$52.20

Quote valid for 30 days from date issued.

Visit us on-line at www.sarisinfrastructure.com

Amount subject to Sales Tax		\$3,166.20	Amount Exempt from Sales Tax		\$0.00	Subtotal (USD):	\$3,166.20
						Invoice Discount:	\$0.00
						Freight Amount:	\$540.00
						Total Sales Tax:	\$0.00
						Total (USD):	\$3,706.20

Terms and conditions:

This quote is valid for 30 days. Pricing and lead time are subject to change after this estimate provided expires.

The item no. QUO-05405, quoted by Saris Infrastructure is an estimate derived from the rate offered by the service provider on the date of the quote. Please be aware that shipping rates are subject to daily fluctuations influenced by various factors, including but not limited to fuel surcharges, specific delivery services (such as unloading at construction sites, residential delivery fees, appointment requirements, lift gate usage, etc.), peak seasons, and the density of the shipped commodities. Due to the dynamic nature of daily rate changes, we diligently strive to align our quotes with current market realities to offer you the most competitive and accurate rates possible. It is essential to note that these rates are estimates and may be adjusted to reflect any changes in the influencing factors. Additionally, any supplementary delivery services required at the point of delivery will be the financial responsibility of the recipient.

Unless otherwise noted, quote does not include additional charges such as lift-gate, construction site, Residential delivery fee, inside delivery, or delivery appointment, etc. Please provide clear information on what services are needed to deliver the goods that may be ordered.

LEAD TIMES: Saris provides estimated lead times when the quote is provided to the customer. Though Saris strives to ship by or before the estimated ship date, we cannot guarantee shipment by that date. The estimated ship date on the order is an estimate only.

ORDERS: Unless otherwise agreed, all orders will be shipped no later than three (3) months (90 days) from the date that Saris accepts the purchase order. For orders that ship after 90days after the order is placed:

- **Partial payment clause:** Orders to be shipped after 90 days of order placement require partial payment of a minimum of 25% of the total order.
- **Escalation Clause on items:** Saris Infrastructure Pricing tables undergo biannual changes, and orders scheduled for shipment after 90 days are not locked at a fixed price. Pricing is subject to change with a maximum annual escalation of 10% for the first year out and 15% for the second year out, based on market conditions, and it applies to orders already placed.
- **Freight Clause:** Saris Infrastructure will provide a new freight rate before shipment due to the unpredictable nature of shipment charges and surcharges. Shipping rates fluctuate daily, influenced by factors such as fuel surcharges, specific delivery services (such as unloading at construction sites, residential delivery fees, appointment requirements, lift gate usage, etc.), peak seasons, and commodity density. While efforts are made to align quotes with market realities, rates are estimates and may be adjusted. Any additional delivery services required at the point of delivery are the recipient's financial responsibility.
- **Storage fee clause:** Customers need to specify a clear shipment timeframe (specific month and year). Orders that are not shipped in the month specified by the customer will be subject to storage fees, excluding changes notified at least 30 days in advance.

DAMAGES IN SHIPMENT: All claims on damages in transit are the responsibility of the Customer and should be filed directly against the carrier. Seller's responsibility ceases on all shipments when a signed bill of lading has been obtained from the carrier.

Modular Corral



Overview:

The Modular Corral combines the intuitive ease of bike docks with the benefit of a freestanding configuration in a multi-space bike rack. Modular in nature, this bike rack can be connected and expanded to fit the given installation area and angled to create additional space and convenience.

Benefits:

- Compatible with both styles of Saris Bike Dock
- Easy access for maintenance and street cleaning
- Can be used freestanding or anchored to surface
- Durable galvanized coat finish is corrosion-resistant and has long-term lifespan
- 4, 6, 8, 10, or 12 bike options
- Meets APBP parking guidelines



Modular Corral

Recommended Setbacks

Features:



Accommodates
4, 6, 8, 10 or 12
bikes



4"x 1.5"
C-channel



Galvanized finish



Temporary anchors: 29173
Permanent anchors: 6259



1 year
warranty



Made in
the USA

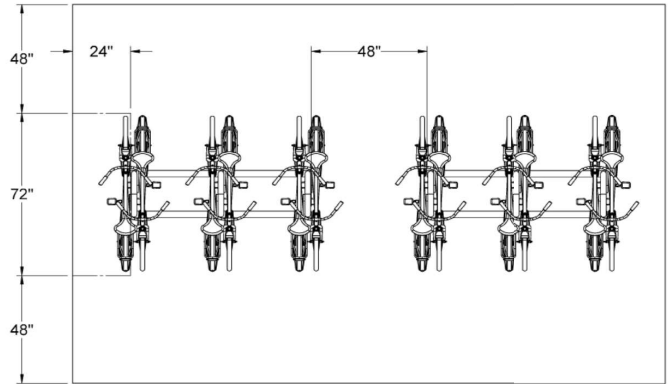

Anchors sold separately

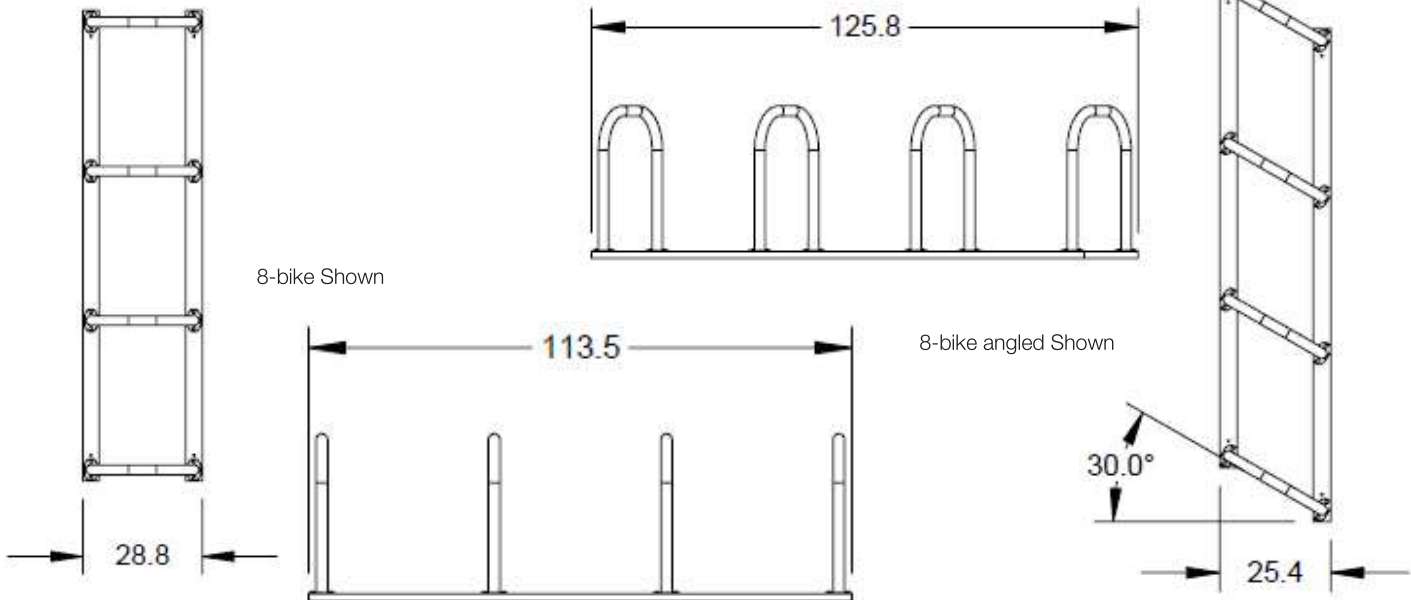

DIMENSIONS

Model #	# Bikes	Length Straight	Length Angled	Width Straight	Width Angled	Height
28360	6	77.45"	89.8"	28.8"	25.4"	35"
28359	4	41.45"	53.8"	28.8"	25.4"	35"
Connector Kit						
28362						